

Boeing 787 Lithium Battery Incidents – Boeing Activities to Support Multiple Complex Investigations

Lori Anglin – Airplane Accident Investigator, Air Safety Investigation, Boeing Commercial Airplanes
John R. Lowell – Technical Fellow, Boeing Research & Technology

I. Event Background

On the morning of January 7, 2013, at about 10:21 AM local time, a Japan Airlines (JAL) Boeing 787-8 experienced an auxiliary power unit (APU) battery failure while parked at a gate at Logan International Airport in Boston, Massachusetts. The event resulted in smoke emanating from the lower fuselage. Upon inspection of the APU battery in the aft electronic equipment bay, minor damage to the surrounding airplane structure was also observed, yet none of the adjacent electronic systems were compromised. No passengers or crew members were aboard the airplane at the time and none of the maintenance or cleaning personnel aboard the airplane were injured. One responding fire fighter experienced a minor injury.

The National Transportation Safety Board (NTSB) sent a senior Systems staff engineer to Boston to document the event. As the airplane was not being readied for flight, the event did not fit the NTSB's investigation criteria so the event was not initially classified as an accident or an incident. The NTSB initially deemed the event as a Special Attention (SA) event. This is a category used by the NTSB to scope out potential events of interest without having to open a formal investigation. The NTSB invited Boeing, the Federal Aviation Administration (FAA), the Bureau d'Enquêtes et d'Analyses pour la sécurité de l'aviation civile (BEA), Japan Airlines (JAL) and Thales to participate in their SA documentation. All parties, including a Boeing Air Safety Investigator (ASI) and several technical staff members, traveled to Boston and the fact gathering and documentation began on January 8, 2013 and continued through January 10, as shown in Figure 1.

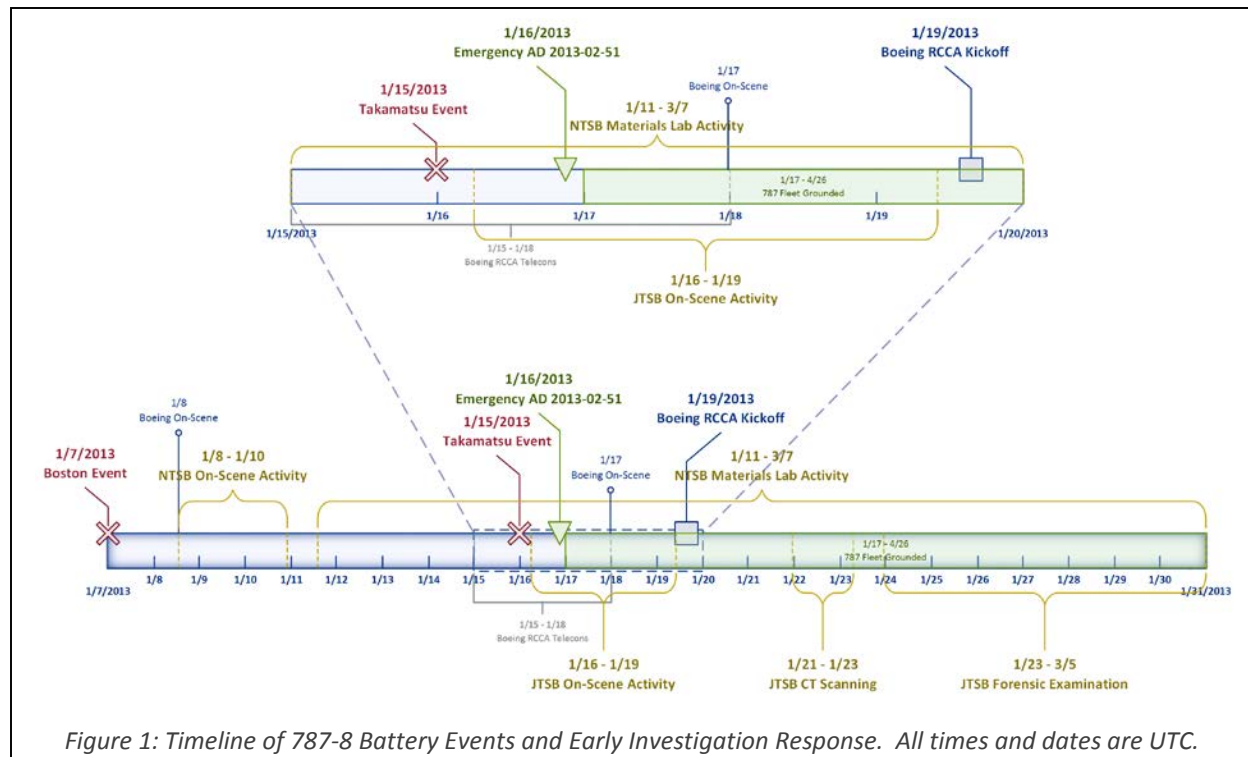

Boeing 787 Lithium Battery Incidents – Boeing Activities to Support Multiple Complex Investigations

The 787-8 has two large-format lithium-ion batteries installed on the airplane: the main battery and the APU battery. Both batteries are identical, but perform different functions. The main battery provides power during ground maintenance operations when no other sources are available (e.g., power-up, refueling, braking, and navigation lights during towing) and provides backup electrical power while airborne. The APU battery provides power to start and operate the APU. The APU may be used on the ground, or in flight, to generate electrical power.

Nine days after the Boston event, on the morning of 16 January at around 8:27AM local time (or 11:27PM UTC on January 15) an All Nippon Airways (ANA) 787-8 experienced a main battery failure in-flight. The crew made a decision to divert to Takamatsu airport and, after consulting with the tower, elected to evacuate the airplane after stopping on a taxiway. There was no airplane structural damage or compromised systems in this event; however four occupants received minor injuries during the evacuation from the airplane. The Japan Transport Safety Board (JTSB) quickly opened an International Civil Aviation Organization (ICAO) Annex 13 investigation and sent personnel to the site. Promptly after learning of this event, a Boeing ASI and a battery engineer traveled to Japan to support the JTSB investigation, as did the NTSB and FAA, arriving on the morning of January 18th local time. At this time, the NTSB also decided to conduct an ICAO Annex 13 investigation of the Boston event.

On January 16, 2013, the same day as the Takamatsu event, the FAA issued Emergency Airworthiness Directive (AD) 2013-02-51, applicable to all The Boeing Company United States (or N-registered) Model 787-8 airplanes. This AD required a modification of the battery system approved by the Seattle Aircraft Certification Office prior to further flight. Other international regulatory bodies likewise issued their own ADs thereby effectively grounding all 50 Boeing 787s in service. Regulatory action also prevented any further deliveries of new airplanes.

II. Boeing Organization of Response

Even before the issuance of the AD, Boeing had gathered executive management, technical experts and project engineers in daily teleconferences to review facts and establish the next steps. Once the AD was issued, a kick-off meeting was held on January 19th to organize an expanded response. At that point, battery experts from all Boeing divisions (who were not already at the NTSB or on-scene with the JTSB) travelled to Everett for the kick-off meeting. The response charter was two-fold: support the NTSB and JTSB investigations and create a solution to get the 787 back in the air.

After much consideration, it was decided that three technical teams were needed to conquer the tasks at hand:

- **Team 1 – Return to Flight.** This team was chartered to focus on the logistics needed to support the fleet that was on the ground throughout the world. It worked with suppliers to ensure that the design changes could be implemented on the fleet to return them to flight as quickly as possible.
- **Team 2 – Root Cause and Corrective Action (RCCA).** This team was chartered to support both the NTSB and JTSB investigations using a formal RCCA process, as well as provide recommendations for corrective actions to prevent future battery failures. We will detail the activities of this group in Section III below.

Boeing 787 Lithium Battery Incidents – Boeing Activities to Support Multiple Complex Investigations

- Team 3 – Alternative Design Actions.** This team was chartered to design and implement the corrective action recommendations from Team 2 and produce a resulting set of design changes along with supporting material needed to address the FAA AD.

Talent was drawn from across the entire Boeing enterprise. A clear demarcation of team responsibilities helped keep the teams focused and allowed for the development of a comprehensive set of solutions in a very short timeframe. Clear team charters also ensured effective lines of communication to the FAA, JTSB, and NTSB. The teams were loosely organized as shown in Figure 2.

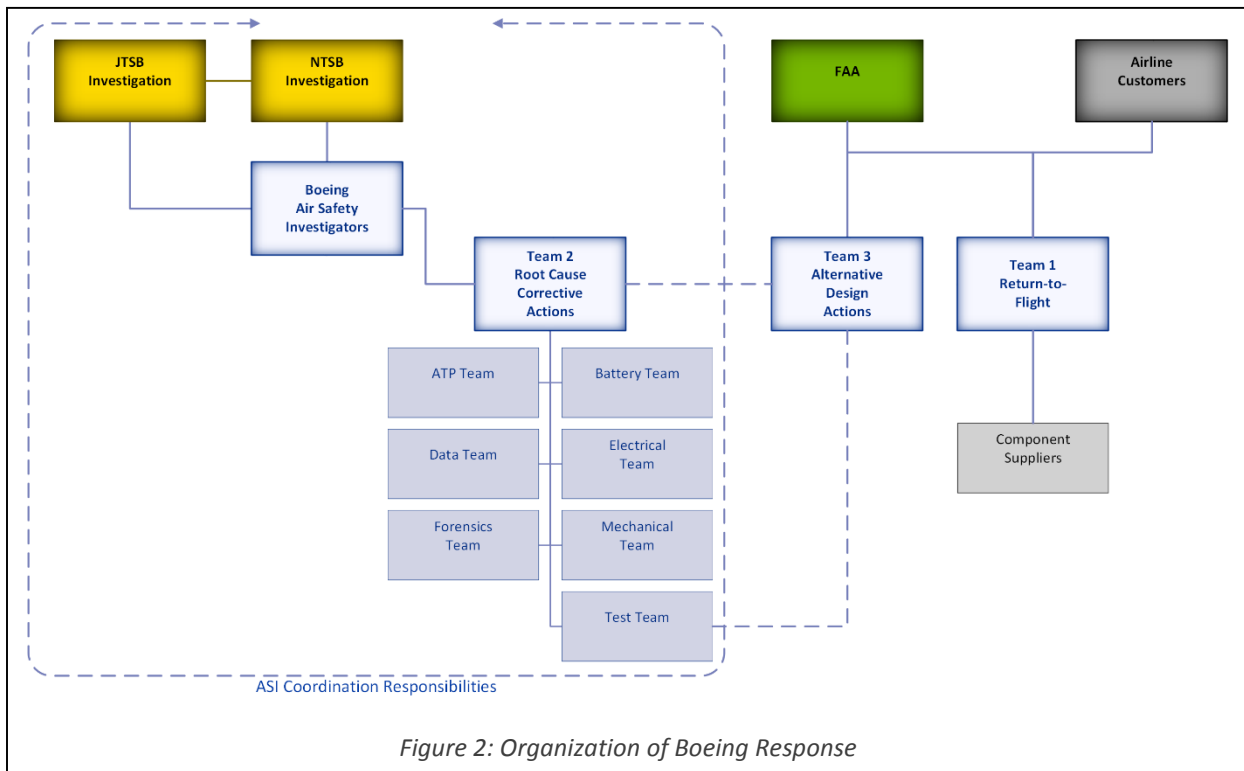

In order to coordinate and communicate the activities of the RCCA team with the external investigations effectively, it was clear that more than the two ASI representatives co-located with the NTSB and JTSB investigations would be needed. The size of the RCCA team quickly grew to several hundred experts so four additional ASIs relocated to the same building as the RCCA team to maximize communication throughout the response and ensure seven-day-a-week coverage. As seen in Figure 1, NTSB and JTSB activities were being held in Japan and Washington DC, as well as at vendor locations in Phoenix, Arizona and France. A rotation schedule was developed to ensure support to all of these activities; for the first few months of the investigations, there was at least one Boeing ASI representative in DC supporting the NTSB and at least one Boeing ASI representative in Japan supporting the JTSB, except for a few days where travel schedule changes interfered.

With so much activity spread across the world, communication among parties was vitally important to keep everyone up to date. For instance, several NTSB staff members traveled to Seattle to participate in RCCA team activities. As the investigation progressed, NTSB staff members would rotate in and out of Seattle, but maintained a presence throughout the effort; the NTSB also had staff members in Japan to support the JTSB investigation directly. ASI representatives participated in multiple RCCA team technical

Boeing 787 Lithium Battery Incidents – Boeing Activities to Support Multiple Complex Investigations

meetings each day so that any investigation-related information was rapidly assimilated. Daily phone calls were held with the NTSB and JTSB home office staff to update them with any new investigation-related information, determine any needed actions, and follow up on those actions assigned earlier.

III. Root Cause and Corrective Actions

In the assembly of the company response to the events, it became clear that the RCCA team would need to coordinate closely with the ongoing investigations by the NTSB and JTSB. However, the RCCA team also had a responsibility to provide corrective action recommendations and assist with producing test data needed to address the FAA Airworthiness Directive. Thus, the RCCA team effort formed a technical hub that aligned Boeing activities with the external investigation efforts.

The RCCA team started out as a moderately sized collection (about 50 people) drawn from throughout The Boeing Company with a variety of engineering backgrounds. Over the course of the next several months, the team grew to several hundred people distributed among the multiple sub-teams shown in Figure 2 and subsequently drew down to a single, small team as the 787 was returned to service.

The remainder of this section of the paper will describe the general Root Cause Investigation process utilized by the RCCA team.

A. Problem identification

The first step in any Root Cause and Corrective Action Process is to clearly identify the problem that is trying to be addressed. An early decision was made by the RCCA team to treat the two events *as if they could have been the result of a common root cause, and then verify this hypothesis during the course of the investigation*. This allowed for centralized management of the root cause investigative process, efficient use of limited resources (such as technical experts within the company), but also required extra diligence during analysis of potential root causes.

B. Causal Analysis

Analysis of potential root causes proceeded in several stages throughout the investigation, but a common element of all stages was the disciplined use of a number of tools to help keep track of the full range of possible causes, clarify the state of understanding for each potential cause, and help assess what actions were needed by the team. Figure 3 shows a high-level depiction of this process.

Boeing 787 Lithium Battery Incidents – Boeing Activities to Support Multiple Complex Investigations

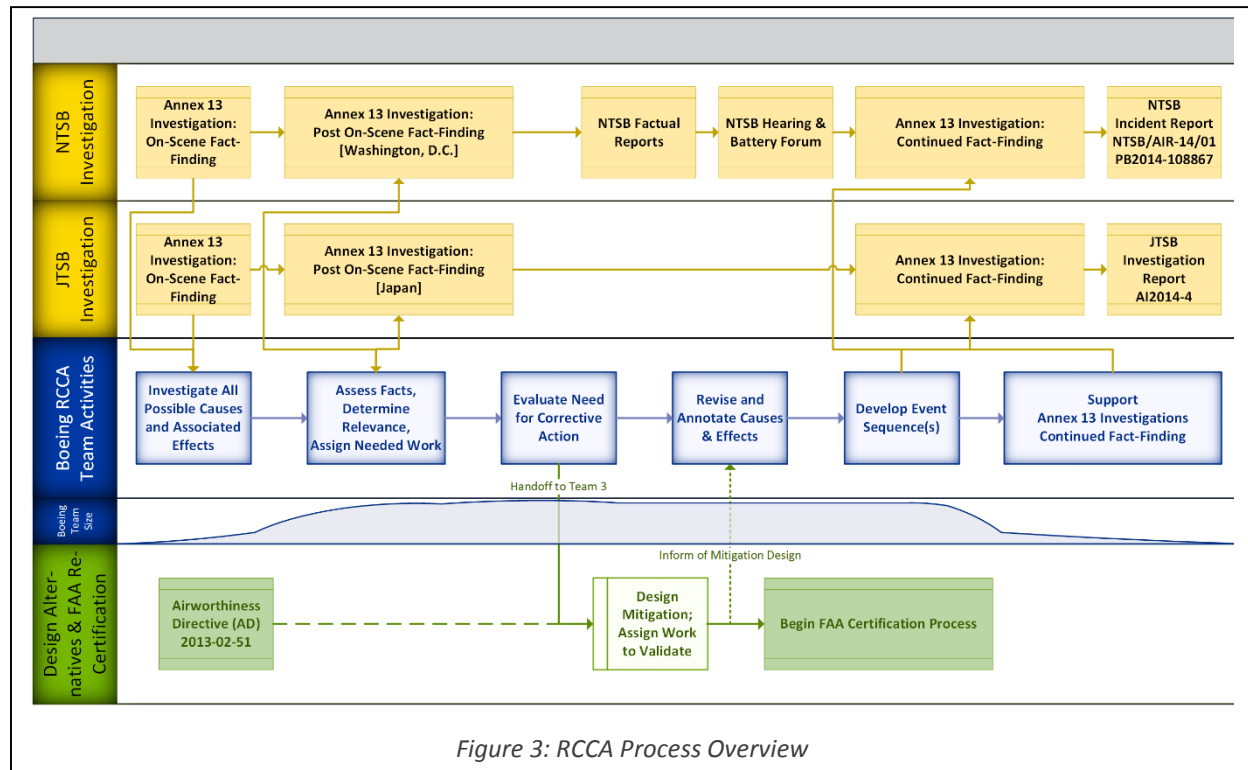

Figure 3: RCCA Process Overview

1. Use of Cause & Effect Diagram

The first of these tools centrally used by the team was a detailed cause and effect (C&E) diagram. A C&E diagram (sometimes called a 5-Why diagram) is a branch diagram that proceeds from the observed effect to a set of high-level causes, each of which is presumed to be the effect of an underlying cause. By continuing this process down through multiple levels, finer and finer levels of detail are exposed until the lowest-level (i.e., root) cause is uncovered. The final diagram shows how lowest-level causes result in effects, which in turn or in combination with other factors, cause further effects that eventually result in the airplane-level observed behavior.

Although an existing failure modes and effects analysis (FMEA) existed for the battery system, it was decided by the team to perform a new, independent analysis for this activity and then consult the existing analysis after the team felt it had neared completion. The rationale for this approach was that it was more likely that the team would uncover new potential failure modes if it did not start its work with a list of investigated faults. Additionally, any modes missed during the brainstorming session could be readily added by consulting the existing analysis.

During an initial brainstorming session, the team developed a number of high-level possible causes for the events and then proceeded to examine the causes for each of those possibilities. This resulted in a complicated C&E diagram, as many items on the chart could alternately be initial causes or effects of other causal events. Over the course of the investigation, the team developed and repeatedly modified an extensive C&E diagram that detailed over 200 potential causal factors for the battery failures. Careful configuration control was exercised to ensure that all activity was captured and updated over the course of the investigation and held within the diagram. Figure 4 shows a notional version of the

Boeing 787 Lithium Battery Incidents – Boeing Activities to Support Multiple Complex Investigations

C&E diagram used by the team, which was printed as a large poster on the wall of the room in which

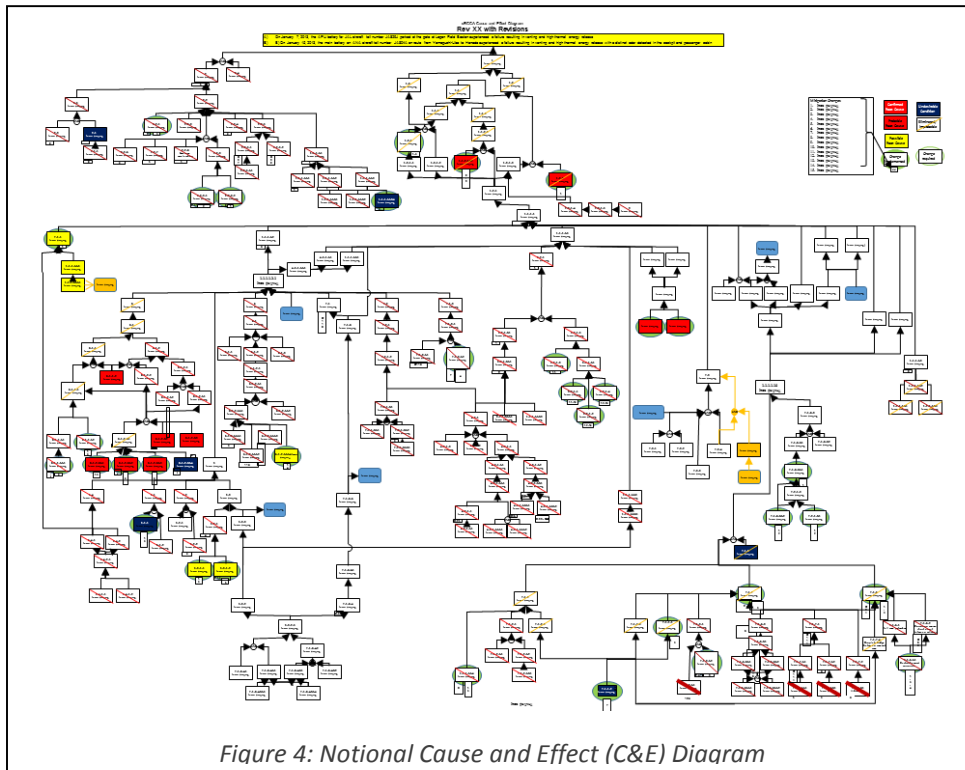

daily RCCA team technical meetings occurred. Both the scale of activity and the complexity of the potential causes are immediately apparent in the structure of the diagram.

2. Assess factual knowledge regarding C&E diagram elements
Having laid out potential causes and effects into an organized C&E diagram, the team worked through

each item in the diagram to assess what was known and what needed to be known about each element. This extensive task served several purposes: first, it ensured that the organization of the C&E diagram was accurate and self-consistent with the current state of knowledge; second, the “need to know” list was used as a starting point for work assignments; and finally, the activity ensured that incoming information could be rapidly sifted and applied to the right concept or set of concepts. This process is depicted in the third process lane of Figure 3.

C. Evaluate potential relevance

A dedicated technical review board (TRB) was formed which convened daily to review factual assessments of C&E diagram elements and coordinate other activities of the RCCA team. The TRB was comprised of a core set of RCCA team members, managers, and technical experts; members of the NTSB, JTSB, and the FAA were invited and often attended these meetings. In particular, the TRB also oversaw evaluations of the potential relevance of a causal element on the C&E diagram. Chart elements were evaluated as being in one of the following categories, and were shown by color coding C&E diagram elements.

Boeing 787 Lithium Battery Incidents – Boeing Activities to Support Multiple Complex Investigations

Category	Description
Eliminated / Improbable	Element not given further consideration as a root cause for the incidents under investigation. <i>[Terminal categorization]</i>
Undesirable Condition	Elements in this category were not root causes, but potential contributory conditions that could alter the probability of a cause or set of causes. <i>[Terminal categorization]</i>
Possible Root Cause	Elements in this category were still under consideration, awaiting disposition into either Probable or Improbable category. <i>[This transitive categorization was re-assessed until a determination could be made to place it elsewhere]</i>
Probable Root Cause	Elements in this category were the set of most-likely root causes. <i>[Terminal categorization]</i>

From a process perspective, every causal element on the diagram started out with an evaluation of “possible root cause.” The team, during the TRB meetings, would reach consensus on work assignments that could fill in the “need to know” facts regarding that element – usually in the form of desired tests or analyses. In some cases, simple reference searches were able to fill in unknowns – that is, they were known to some, but not to those on the team. Work assignments were then managed by a number of sub-teams – mechanical, electrical, etc. – until they were ready for further review by the TRB. Due to the limited number of test facilities and batteries available for testing, all tests were managed through a Test sub-team. This ensured that all tests were prioritized against available resources and the increase in knowledge associated with the test. A detailed depiction of this part of the RCCA process is shown in Figure 5; a high-level view is shown in Figure 3.

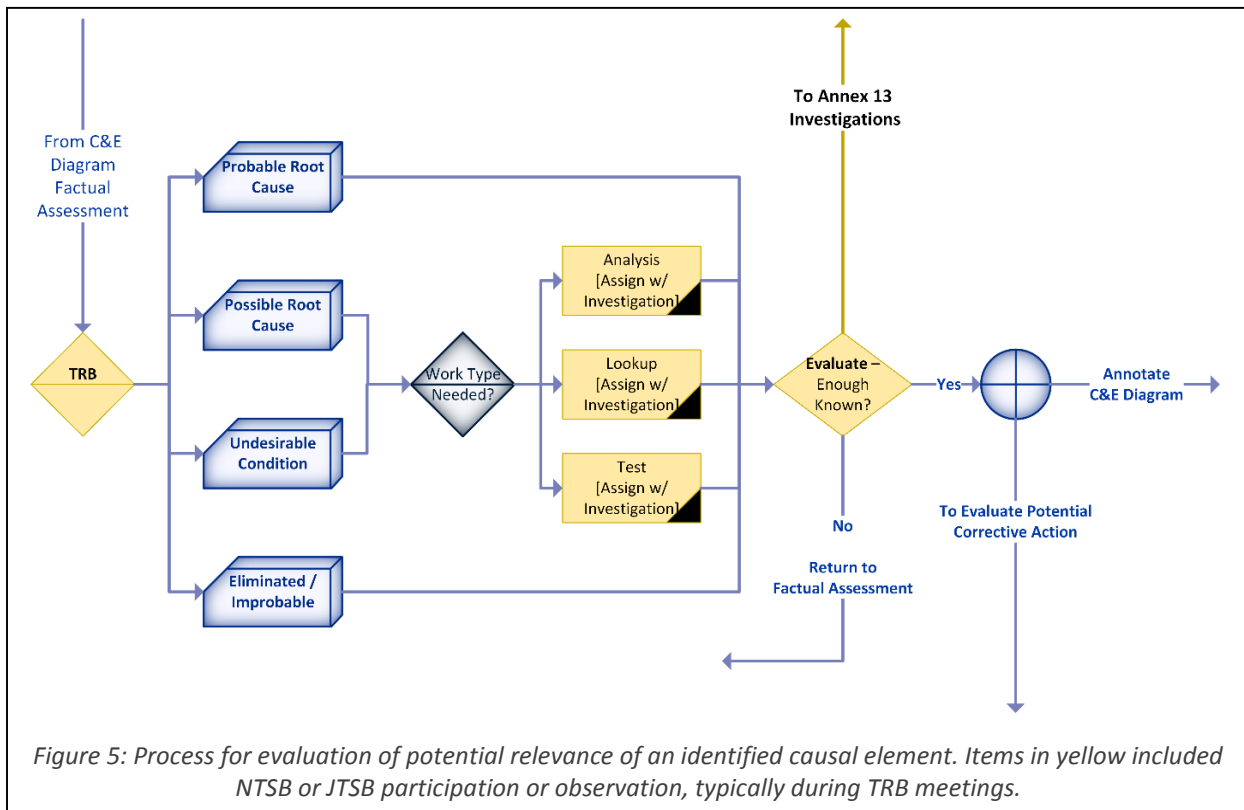

Figure 5: Process for evaluation of potential relevance of an identified causal element. Items in yellow included NTSB or JTSA participation or observation, typically during TRB meetings.

Boeing 787 Lithium Battery Incidents – Boeing Activities to Support Multiple Complex Investigations

The C&E diagram records included tables containing fields that enabled reconstruction of the thought process that went into TRB decisions. Using this approach, the RCCA team was able to expand and contract rapidly to accommodate the required workload. As stated previously, at its peak, the RCCA team totaled over 500 people. This process also enabled organized tracking of all activities in light of their contribution to the overall understanding of probable root cause. By having the TRB responsible for work assignments and disposition of completed assignments, quality control and centralized record keeping was able to be exercised throughout the effort. In fact, the number of items in the “possible root cause” category was tracked throughout the RCCA team activity to ensure that the efforts of the team drove it to smaller and smaller numbers.

D. Evaluate potential corrective action

After work assignments were completed, the results were briefed back to the TRB; often this occurred many days after the work assignment was made. For items that had not been eliminated as improbable, an assessment was made regarding the potential need to make a corrective action to address that particular cause. Corrective action changes were considered desired if the pool of available data indicated a clear method either to reduce the likelihood of the particular cause occurring, or to mitigate the effect or chain of effects that would result from that particular cause. The C&E diagram enabled the team to focus on recommended actions that addressed contributing elements to multiple pathways, or mitigating the effects of numerous root causes, thereby making substantial improvements in the overall safety of the battery system despite having not arrived at a single root cause at the time. These determinations fell into three categories:

Change Descriptor	Description
Not Desired	Available data not indicative of clear potential change that addresses the cause under consideration.
Change Desired	Available data indicate clear potential for change(s) that result in either (a) a reduced likelihood that the cause under consideration could occur, or (b) a reduction in the severity of the effect(s) that would result from the element under consideration, should it occur. Items in this category were communicated to Team 3 for assessment of design alternatives.
Change Implemented	A desired change that resulted in an alternative design and subsequent re-certification activity was deemed implemented.

If an item was determined to have a desired change, a description of the element under consideration and the desired change was given to Team 3 (Design Alternatives) for their evaluation. Members of that team would determine alternative approaches consistent with the desired change, develop an alternate design, and perform engineering analysis and testing to validate their design. Due to limited availability of test resources, Team 3 tests were coordinated through the RCCA test team; however, their tests used a combination of RCCA test team members and embedded members of Team 3 to ensure the tests were able to validate the needed elements of the alternative design. Team 3 tests were reviewed at a later time to determine if data relevant to the NTSB or JTSB investigations were produced during the course of testing; were this determined, that information was communicated back to those investigations. In

Boeing 787 Lithium Battery Incidents – Boeing Activities to Support Multiple Complex Investigations

all, the Team 3 engineering work served as an input for the subsequent re-certification effort for the battery system. This process is shown in Figure 6 above, and an overview is shown in Figure 3.

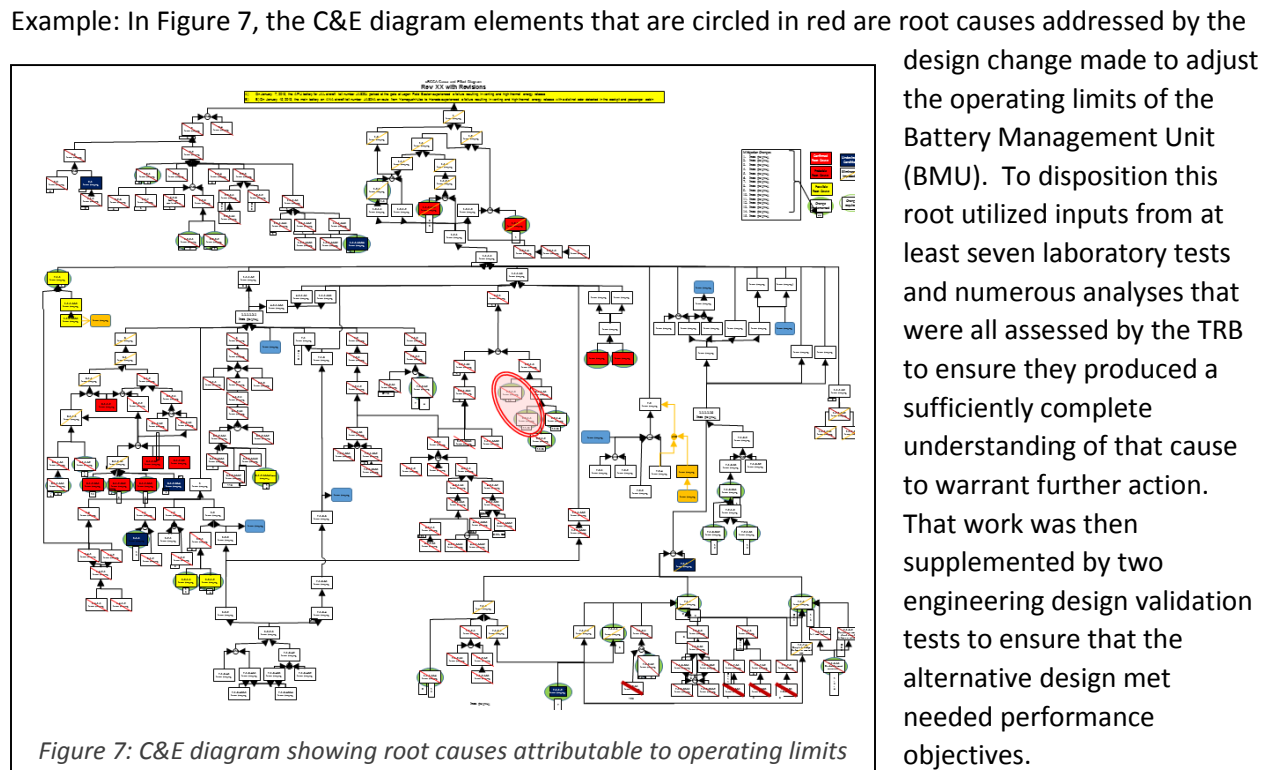
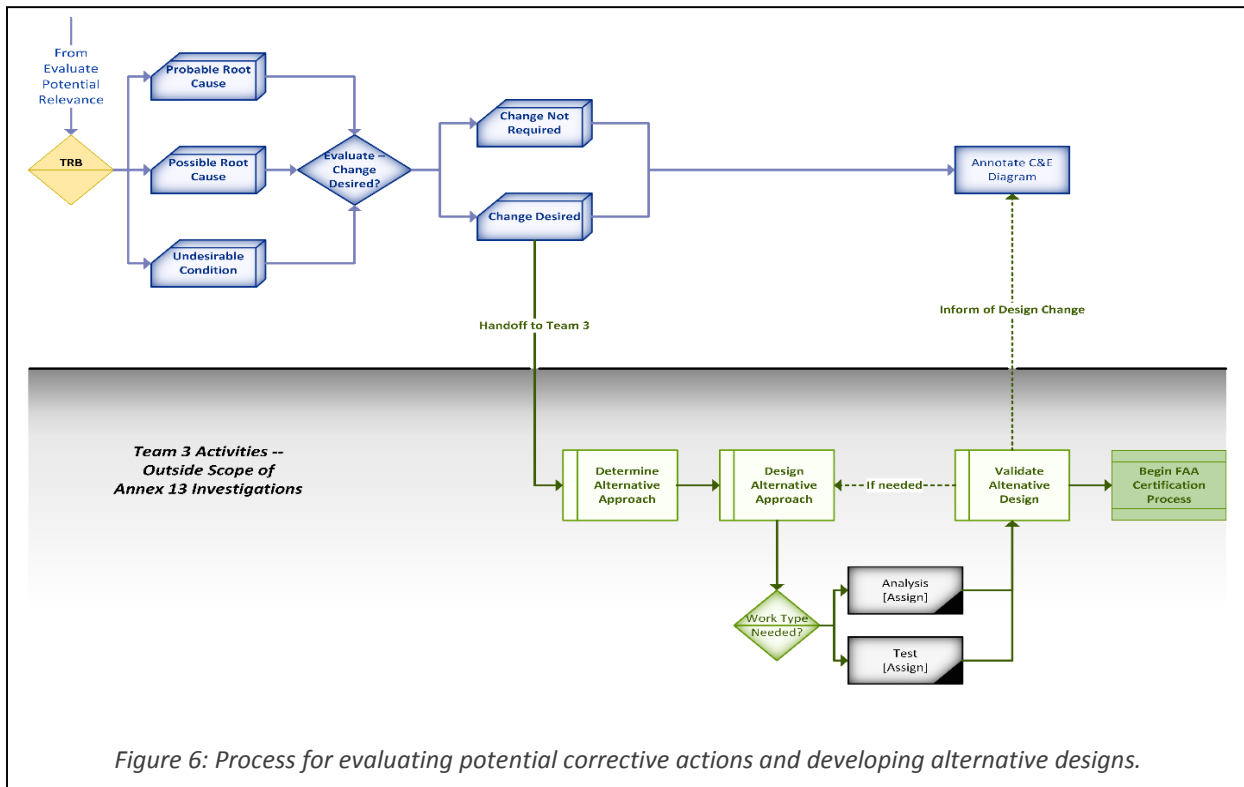

Boeing 787 Lithium Battery Incidents – Boeing Activities to Support Multiple Complex Investigations

E. Event Sequence development and communication

While the causal analysis was going on as described above, a small group of experts were closely involved with the detailed NTSB and JTSB forensic investigation efforts which focused on trying to reconstruct the sequence of events that occurred during each incident. While each agency employs a different investigative process, both attempt to determine root cause through temporally structuring a sequence of events based on analysis of forensic evidence. This required separately placing technical staff members (and ASI investigators) on-site with each investigative agency's designated analysis laboratory, in Washington, D.C. for the NTSB and in Japan for the JTSB. These people, along with Boeing's ASI team, worked directly with those organizations and facilitated communication and coordination with activities ongoing at Boeing facilities.

As described above, the Boeing RCCA process considers all possible causes and eliminates those that are improbable given the available data, with the idea being that the probable cause will survive and the process will ensure that nothing is overlooked. This process, however, does not necessarily produce a temporal forensic sequence of events similar to what the NTSB and JTSB investigations are trying to produce. Therefore, after the C&E diagram came into sufficient focus, the team produced a set of event sequences that were consistent with the entire corpus of data available. Each event sequence started with a probable root cause and then described a chain of events (including reference to the supporting forensic and test evidence) that would result in one (or both) of the incident events. These sequences greatly streamlined the explanation of the incident events and made them accessible to a wider audience. The developed event sequences were reviewed by the TRB, and presented to both the NTSB and JTSB for consideration.

IV. Additional Investigation Support

A. NTSB Hearing and Battery Forum Support

While the RCCA work described above was in progress, and concurrent with the release of their interim report on March 7, the NTSB announced they would hold a Public Investigative Hearing covering the Battery Investigation and a forum entitled "Lithium Ion Batteries in Transportation," both in April 2013. As party to the NTSB Investigation, Boeing was required to participate in the hearing; Boeing representatives attended the forum. Although both public hearings and transportation safety forums are within the NTSB's operating charter, they are not normally held so close together. These activities required additional support, and coordination with the JTSB investigation and Team 3 activities.

B. Continued Fact-Finding Support

After the NTSB Public Investigative Hearing concluded, both the NTSB and JTSB investigations developed a series of tests to refine their assessments of root cause; these tests occurred throughout the latter part of 2013 and through the Spring of 2014. Note that on April 19, 2013 the FAA certified a new battery design and installation for the 787. After this time, all 787 aircraft were either retrofitted with this new design, or were delivered with the new design in place. Thus the NTSB and JTSB tests being conducted during this period were performed on batteries that were no longer in service. In some cases, these tests were refinements of test activities performed by the Boeing RCCA team; while in other cases, tests were devised to probe alternate hypotheses regarding the root cause of the battery events. The resulting series of tests and meetings took place at multiple locations in the United States, Asia, and Europe. For each test or meeting, a Boeing RCCA team representative and an ASI worked with the NTSB

Boeing 787 Lithium Battery Incidents – Boeing Activities to Support Multiple Complex Investigations

and JTSB investigation teams to devise and refine test purpose, procedures, and instrumentation; participated or observed test activities; and went over post-test analysis.

C. Investigation Close-out activities

The NTSB and JTSB had very different close-out processes that required different levels of input, attention, and coordination from Boeing.

The JTSB process is a typical ICAO Annex 13 process, in which the JTSB produces a draft investigation report documenting the findings and recommendations based on material collected throughout the investigation. In this case, the RCCA team had produced a number of presentations and report summaries that had been shared with the NTSB and JTSB throughout the investigation. After the JTSB produced their draft report, participants were requested to provide comments on the draft report per typical Annex 13 procedures. Again, Boeing RCCA team members and Boeing ASI worked together to produce a single set of comments that were returned via the NTSB to the JTSB for their consideration prior to publication of the final investigation report on September 25, 2014.

The NTSB investigation close-out process is substantially more involved. The NTSB first conducts a factual review of all documents produced during the course of the investigation. During this review, all parties are requested to verify the factual accuracy of and identify any factual inconsistencies in the produced documents; based on that input, they should also suggest revisions that are more representative of agreed upon facts. For this investigation, that review took place during two separate in-person meetings at the NTSB, and considered approximately 20 documents containing over 1,700 pages of content. Additionally, a proprietary information review of the same set of documents was conducted with a goal of limiting the release of proprietary information in the NTSB factual reports. The net output of these two reviews was a final set of NTSB factual reports agreed upon by all parties to the investigation that were released to the investigation docket.

The NTSB factual reports then served as the foundation for each party to produce a submission report to the investigation, should they choose to do so. The submission report summarizes each party's analysis and interpretation of the collected and agreed upon facts, their findings of probable root cause, and any proposed safety recommendations. Again, Boeing RCCA and ASIs worked together to write this document. In most cases, the parties have 30 days to produce their submission from the time the factual review is completed; however, in this investigation, the extended factual and proprietary reviews overlapped with a substantial portion of that period of time and made accurate citation of source material difficult.

The NTSB staff used the factual reports in the public docket to produce a draft final report. U.S.- participants such as Boeing were not able to participate in the analysis or writing of this report; however, the draft report was shared with non-U.S. participants in the investigation who were able to collect comments and recommendations from non-U.S. parties and forward them back to the NTSB (typical for all Annex 13 investigations). As a rule, the NTSB does not provide this opportunity to U.S. parties of their investigations, a marked difference from the typical ICAO Annex 13 investigation process. After receiving this feedback from the other ICAO organizations, the NTSB staff forwarded the draft report to the Safety Board members, who approved the final report for publication on November 21, 2014.

Boeing 787 Lithium Battery Incidents – Boeing Activities to Support Multiple Complex Investigations

V. Conclusions

The RCCA process worked alongside the NTSB and JTSB investigations and required constant communication between all parties. However, from a process perspective, the net result of the RCCA process was a set of recommendations that served as the basis for subsequent battery improvements. Those design and manufacturing changes have been implemented in all in-service 787 airplanes, prevent possible airplane-level safety effects, and ensure safe flight and landing in the event of any main or APU battery venting event.